

A90-90P40

WC connector – Elbow 90° with connecting pitches DN40

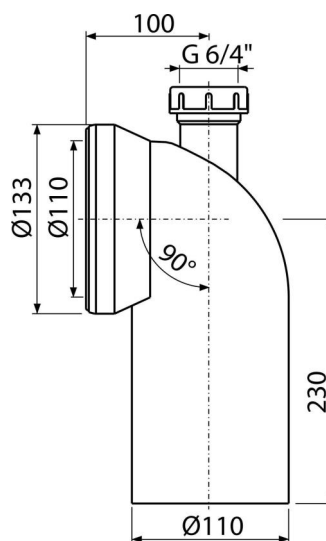

Application

To connect the WC bowl to the drain pipe

Features

- Material: polypropylene
- Possibility of connecting washbasin waste Ø40 mm or an air admittance valve
- Waste outlet connection 110 mm
- Inclination angle 90°

Scope of supply

- Elbow
- Seal

Order number, Logistic information

Code	EAN	Weight (piece packing palett)	Dimensions (piece packing)	Quantity (packing palett)
A90-90P40	8594045930597	0,49 5,94 115,0 kg	220x135x155 590x430x390 mm	12 192 pcs

Warranty 2/2 years * Customs code 39174000