

A90-45

WC connector – Elbow 45°

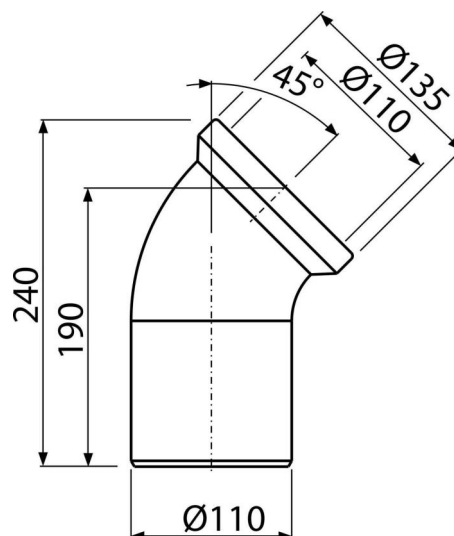

Application

To connect the WC bowl to the drain pipe

Features

- Material: polypropylene
- Connection to waste Ø110 mm
- Inclination angle 45°

Scope of supply

- Elbow
- Seal

Order number, Logistic information

Code	EAN	Weight (piece packing palett)	Dimensions (piece packing)	Quantity (packing palett)
A90-45	8594045931822	0,29 5,73 111,6 kg	240x135x150 590x430x390 mm	20 320 pcs

Warranty
2/2 years *

Customs code
39174000