

A90-22

WC connector – Elbow 22°

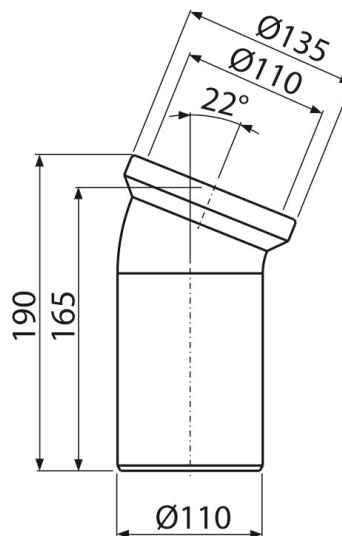

Application

To connect the WC bowl to the drain pipe

Features

- Material: polypropylene
- Connection to waste Ø110 mm
- Inclination angle 22°

Scope of supply

- Elbow
- Seal

Order number, Logistic information

Code	EAN	Weight (piece packing palett)	Dimensions (piece packing)	Quantity (packing palett)
A90-22	8594045931839	0,35 7,08 133,3 kg	190x135x140 590x430x390 mm	20 320 pcs

Warranty

2/2 years *