

A90-90

WC connector – Elbow 90°

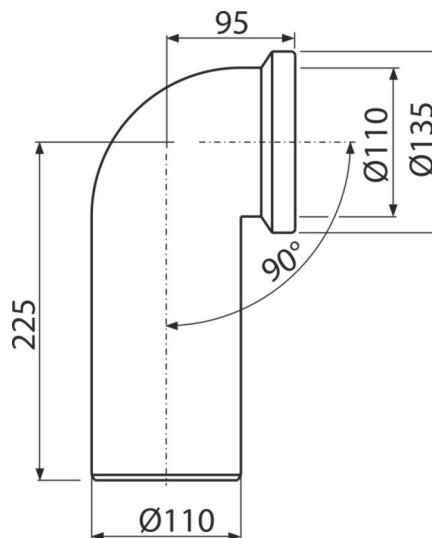

Application

To connect the WC bowl to the drain pipe

Features

- Material: polypropylene
- Connection to waste Ø110 mm
- Inclination angle 90°

Scope of supply

- Elbow
- Seal

Order number, Logistic information

Code	EAN	Weight (piece packing palett)	Dimensions (piece packing)	Quantity (packing palett)
A90-90	8594045931846	0,41 4,92 98,7 kg	260x110x150 590x430x390 mm	12 192 pcs

Warranty 2/2 years *	Customs code 39174000
--------------------------------	---------------------------------