

# APS1

External washing machine trap, chrome DN32

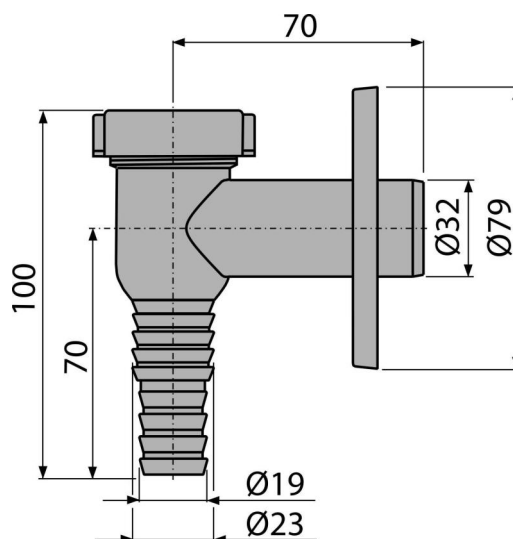

### Application

To connect the washing machine or dishwasher

### Features

- Material: ABS – chrome-plated
- Hose connection Ø19 and Ø23 mm
- Connection to waste pipe Ø32 mm
- Service access for easy cleaning
- Dry odour flap against odours from the sewer

### Scope of supply

- Odour trap ball with a spring
- Chrome-plated plastic rosette
- Waste and trap body

### Order number, Logistic information

Code	EAN	Weight (piece   packing   palett)	Dimensions (piece   packing)	Quantity (packing   palett)
APS1	8594045933710	0,08   7,53   230,8 kg	100x80x90   590x240x390 mm	100   2800 pcs

**Warranty**  
2/3 years \*

**Norms**  
EN 274