

APV16

Floor drain 150×150/50 mm straight outlet, grey grid, wet odour trap

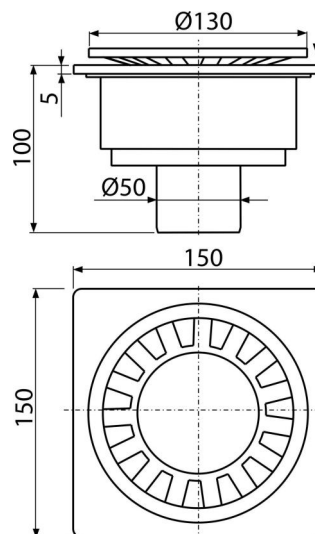

Application

For wheelchair access
 For drainage of floor level showers
 For the interior, where will be frequent use associated with the regular water runoff into the floor drain (bathrooms)

Features

- Material: ABS
- Plastic grid Ø130 mm
- Straight connection to waste Ø50 mm
- Wet odour trap prevents the penetration of odours from the sewer

Scope of supply

- Plastic grid with integrated wet odour trap – white
- Drain body Ø50 mm, straight outlet

Order number, Logistic information

Code	EAN	Weight (piece packing palett)	Dimensions (piece packing)	Quantity (packing palett)
APV16	8594045934793	0,30 5,92 114,7 kg	110×150×150 590×240×390 mm	20 320 pcs

Warranty

2/6 years *

Norms

EN 1253

Technical specifications

- Total installation height 100 mm
- Waste pipe diameter 50 mm
- Flow of the inlet grid 24 l/min
- Load class K3 300 kg
- Odour trap 20 mm