

M90

Legs for pre-wall installation systems

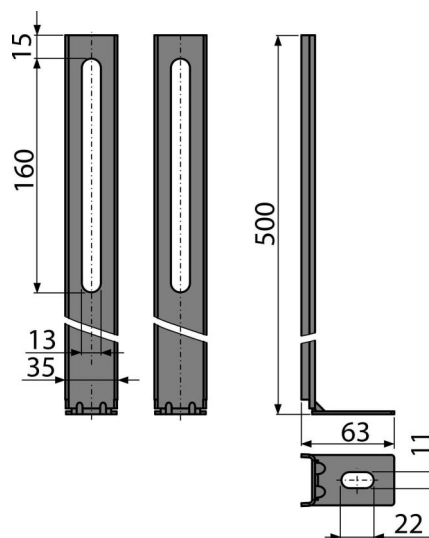

Application

For pre-wall installation systems AM100 and AM115

Features

- Material: powder-coated metal
- Allows you to install AM100 and AM115 systems without bricking underneath

Scope of supply

- Fixation set: screw $\text{Ø}8 \times 60$ – 2 pcs, dowel $\text{Ø}12$ – 2 pcs
- Nut with washer for fastening to the pre-wall installation system 2 pcs
- Pair of feet

Order number, Logistic information

Code	EAN	Weight (piece packing palett)	Dimensions (piece packing)	Quantity (packing palett)
M90	8594045936339	0,93 0,93 - kg	450x50x125 - mm	1 - pc

Warranty

2/2 years *