

A461-50

Shower waste and trap

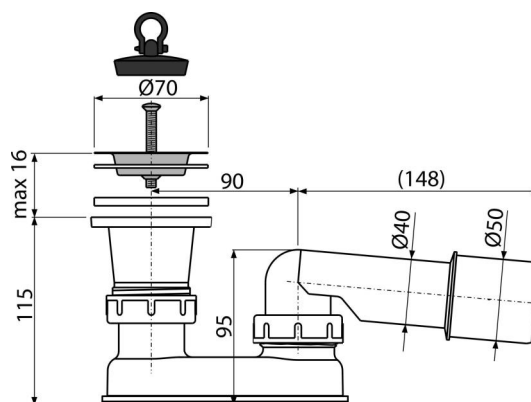

Application

To drain the water from the shower trays
 For shower trays without overflow
 For shower trays with a drain outlet Ø50 mm

Features

- Connection to waste pipe Ø40/50 mm

Scope of supply

- Chrome-plated stainless steel outlet grid
- Floor drain
- Odour trap of polypropylene, thermally and chemically resistant
- PVC plug

Order number, Logistic information

Code	EAN	Weight (piece packing palett)	Dimensions (piece packing)	Quantity (packing palett)
A461-50	8594045936988	50 mm 0,22 10,94 195,0 kg	260×90×140 590×430×390 mm	50 800 pcs

Warranty

2/3 years *

Norms

EN 274

Technical specifications

- Resistance of odour trap against the pressure 588 Pa
- Flow rate 48,6 l/min
- Thermal resistance 95 °C
- Odour trap 50 mm