

# A840-DN50/40

Sink waste and pipe trap with stainless steel grid DN70, two connectors and flexi pipe

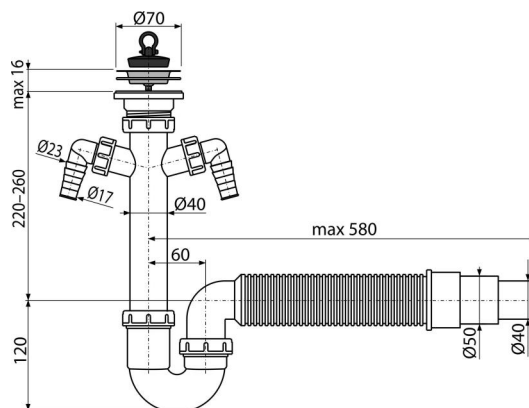

### Application

For sink

### Features

- Two connectors for connecting washing machines or dishwashers
- Material: polypropylene
- Connection to waste pipe flexi Ø40/50 mm

### Scope of supply

- Flexi pipe
- Stainless steel outlet grid
- Shower trap body with two connectors
- PVC plug

### Order number, Logistic information

Code	EAN	Weight (piece   packing   palett)	Dimensions (piece   packing)	Quantity (packing   palett)
A840-DN50/40	8594045937442	50 mm 0,46   4,58   148,2 kg	500×110×220   590×240×390 mm	10   280 pcs

### Warranty

2/3 years \*

### Norms

EN 274

### Technical specifications

- Hose connector 17 mm
- Flow rate 60 l/min
- Thermal resistance 95 °C
- Odour trap 64 mm