

# A45B

## Urinal trap horizontal outlet DN40

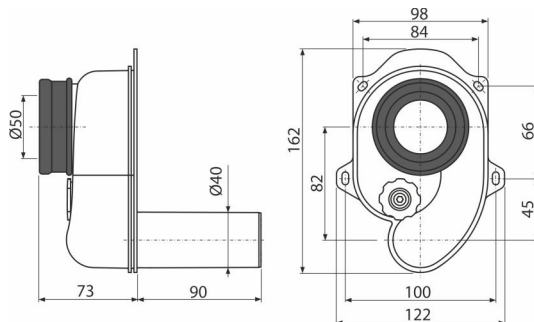

### Application

For urinal with rear outlet  
For installation into the wall

### Features

- Material: polypropylene
- Connection to waste pipe  $\varnothing 40$  mm
- Connection to urinal  $\varnothing 50$  mm
- Rings for fixing at the installation site
- Self-cleaning design of trap
- Service access for easy cleaning
- Horizontal outlet
- High flow rate

### Scope of supply

- Waste and trap body with cleaning aperture
- Wrapping seal

### Order number, Logistic information

Code	EAN	Weight (piece   packing   palett)	Dimensions (piece   packing)	Quantity (packing   palett)
A45B	8594045937596	0,20   4,93   158,1 kg	170x130x170   590x240x390 mm	25   700 pcs

Warranty  
2/3 years \*

Norms  
EN 274

### Technical specifications

- Flow rate 42 l/min