

A45C

Urinal trap vertical outlet DN40 and DN50

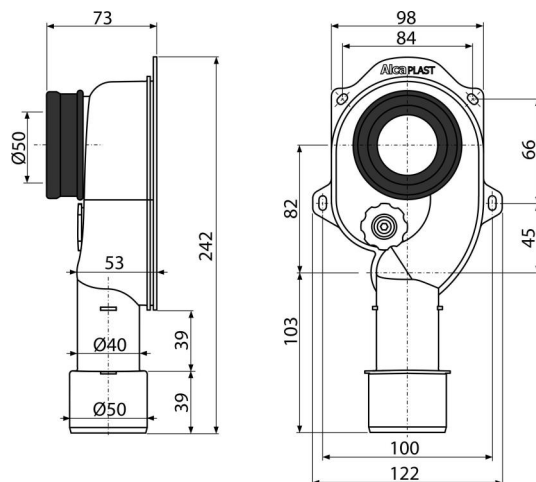

Application

For urinal with rear outlet
For installation into the wall

Features

- Installation stoppers to connect HT50
- Material: polypropylene
- Connection to waste pipe Ø40/50 mm
- Connection to urinal Ø50 mm
- Service access for easy cleaning
- Straight outlet pipe

Scope of supply

- Waste and trap body with cleaning aperture
- Wrapping seal

Order number, Logistic information

Code	EAN	Weight (piece packing palett)	Dimensions (piece packing)	Quantity (packing palett)
A45C	8594045937602	0,20 5,01 160,2 kg	250×130×80 590×240×390 mm	25 700 pcs

Warranty	Customs code	Norms
2/3 years *	39229000	EN 274

Technical specifications

- Flow rate 40,8 l/min