

AKS1

Funnel trap for dripping condensate DN32

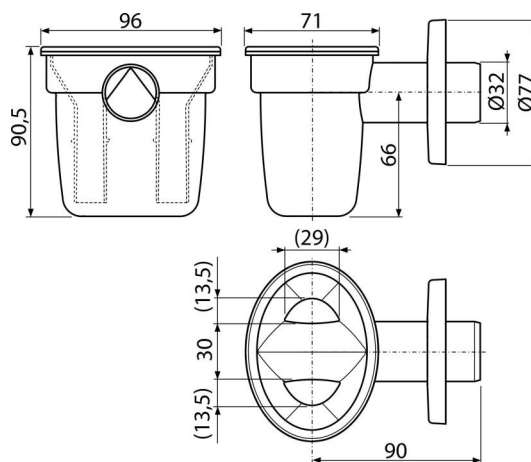

Application

To capture the dripping condensation

Features

- Material: polypropylene
- Connection to waste pipe Ø32 mm
- Wet odour trap

Scope of supply

- Plastic rosette
- Waste and trap body

Order number, Logistic information

Code	EAN	Weight (piece packing palett)	Dimensions (piece packing)	Quantity (packing palett)
AKS1	8594045939118	0,13 6,27 195,6 kg	125x92x100 590x240x390 mm	50 1400 pcs

Warranty

2/3 years *

Norms

EN 274

Technical specifications

- Flow rate 16,8 l/min
- Thermal resistance 95 °C
- Odour trap 50 mm