

M909

Double elbow 90° with sealing

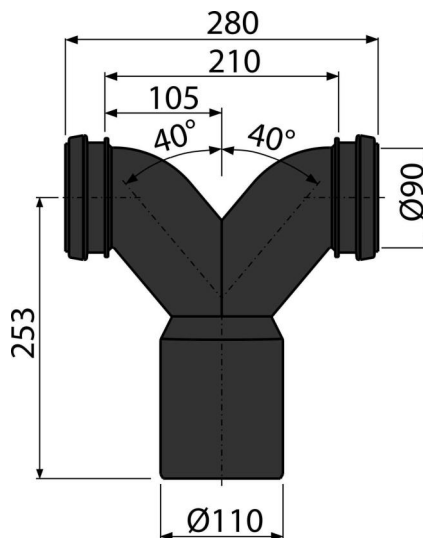

Application

To install two wall-hung WC pans back-to-back of each other using one waste

pipe

For installation in plasterboard structures

For pre-wall installation systems

Features

- Material: polyethylene

Scope of supply

- Fixation ring 2 pcs
- Double waste elbow Ø90/110 mm
- Seal 2 pcs

Order number, Logistic information

Code	EAN	Weight (piece packing palett)	Dimensions (piece packing)	Quantity (packing palett)
M909	8595580501914	0,64 6,40 122,4 kg	300x280x110 590x430x390 mm	10 160 pcs

Warranty

2/2 years *

Norms

EN 476, EN 12056-5