

APV5111

Floor drain 105×105/50 mm side outlet, grey grid, wet odour trap

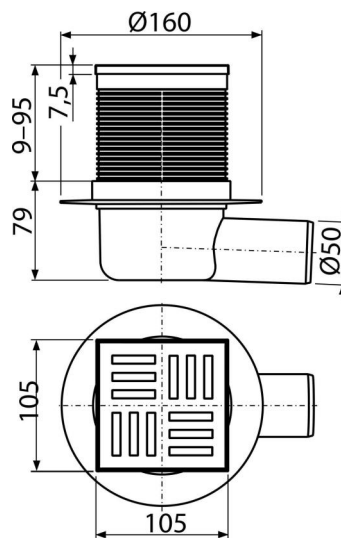

Application

For wheelchair access
For the interior, where will be frequent use associated with the regular water runoff into the floor drain (bathrooms)

Features

- Side connection to waste Ø50 mm
- Insulation collar for connection to waterproofing of the building
- Compatibility with floor drains parts including wet, dry and combined odour trap SMART
- Material: polypropylene resistant to mechanical, chemical and thermal damage
- Mechanically cleanable trap up to the waste pipe
- Plastic grid 102×102×4 mm
- Wet odour trap prevents the penetration of odours from the sewer
- Height adjustable throat 9–95 mm

Scope of supply

- Floor drain throat 105×105 mm
- Plastic grid – gray
- Seal kit
- Floor drain body Ø50 mm, side outlet
- Wet odour trap

Order number, Logistic information

Code	EAN	Weight (piece packing palett)	Dimensions (piece packing)	Quantity (packing palett)
APV5111	8595580507060	0,39 7,73 143,7 kg	280×120×190 590×430×390 mm	20 320 pcs

Warranty
2/6 years *

Norms
EN 1253

Technical specifications

- Total installation height 88-174 mm
- Resistance of odour trap against the pressure 480 Pa
- Waste pipe diameter 50 mm
- Flow of the inlet grid 46 l/min
- Load class K3 300 kg
- Wet odour trap 51 mm