

# APV0030

Dry odour trap

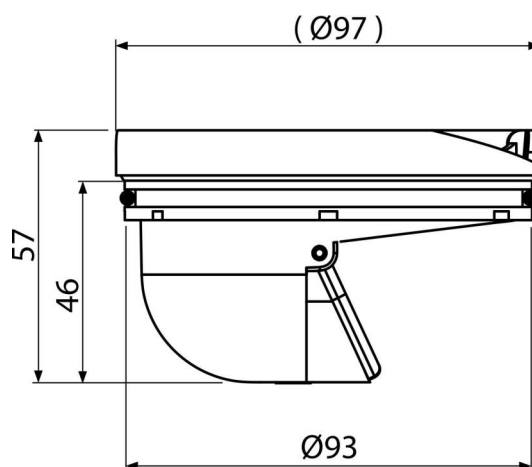

### Application

For floor drains  
For outdoor use

### Features

- Material: polypropylene resistant to mechanical, chemical and thermal damage
- Mechanical closure of dry odour trap prevents the penetration of odours from the sewer

### Scope of supply

- Odour trap flap
- Lock ring
- Odour trap body
- Seal

### Order number, Logistic information

Code	EAN	Weight (piece   packing   palett)	Dimensions (piece   packing)	Quantity (packing   palett)
APV0030	8595580507510	0,07   3,61   121,1 kg	98x58x98   590x240x390 mm	50   1400 pcs

**Warranty** 2/2 years \*    
 **Customs code** 39269097    
 **Norms** EN 1253

### Technical specifications

- Pressure resistance 270 Pa
- Flow rate 57-62 l/min