

# APV0050

Wet odour trap for APV26, APV26C

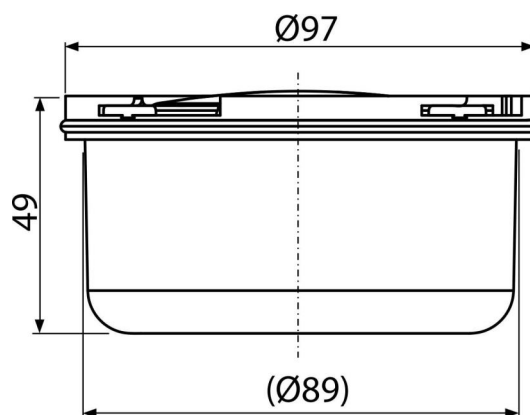

### Application

For floor drains APV26, APV26C  
For interior use

### Features

- Material: polypropylene resistant to mechanical, chemical and thermal damage
- Wet odour trap prevents the penetration of odours from the sewer

### Scope of supply

- Odour trap body
- Seal
- Odour trap cover

### Order number, Logistic information

Code	EAN	Weight (piece   packing   palett)	Dimensions (piece   packing)	Quantity (packing   palett)
APV0050	8595580507534	0,07   3,59   120,5 kg	98x50x98   590x240x390 mm	50   1400 pcs

### Warranty

2/2 years \*

### Norms

EN 1253

### Technical specifications

- Pressure resistance 260 Pa
- Flow rate 32 l/min
- Odour trap 25 mm