

P065-ND

Odour trap for plastic shower drain

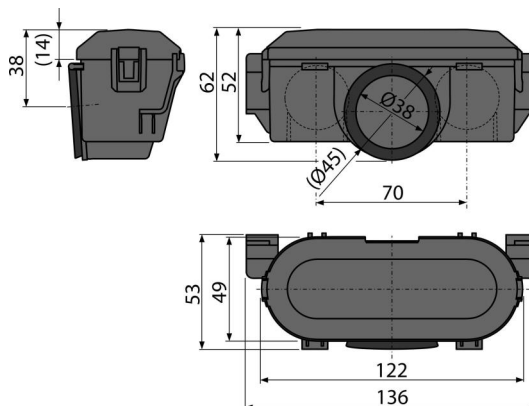

Application

For linear shower drain APZ8, APZ9, APZ10, APZ18, APZ10BLACK

Features

- Combined odour trap SMART

Scope of supply

- Ball 2 pcs
- Seal 2 pcs
- Odour trap

Order number, Logistic information

Code	EAN	Weight (piece packing palett)	Dimensions (piece packing)	Quantity (packing palett)
P065-ND	8595580512088	0,07 0,07 - kg	mm	1 - pc

Warranty 2/2 years * Customs code 39269097

Technical specifications

- Resistance of odour trap against the pressure 640 Pa
- Flow rate 31 l/min
- Odor trap combined with a water seal 29 mm