

M900

Accessories set

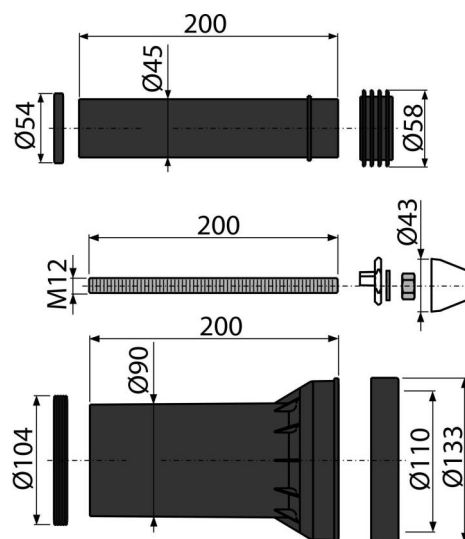

Application

For connecting water and waste to the WC – set
For pre-wall installation systems

Features

- Material: polypropylene, galvanized

Scope of supply

- Fixation material for fixing the WC pan: threaded rod M12 – 2 pcs, washers – 4 pcs, cover – 2 pcs, nut – 2 pcs, thread protector – 2 pcs
- Direct socket for connecting a wall-hung WC bowl to the waste pipe, polypropylene, Ø90 mm, including seals
- Jumper for connection of wall-hung WC pan to the water supply from the cistern, polypropylene, Ø45 mm, including seals and wrapping seal

Order number, Logistic information

Code	EAN	Weight (piece packing palett)	Dimensions (piece packing)	Quantity (packing palett)
M900	8595580514266	0,79 11,82 209,1 kg	200x133x133 590x430x390 mm	15 240 pcs

Warranty
2/2 years *

Norms
EN 476