

AKS2

Trap for dripping condensate DN40

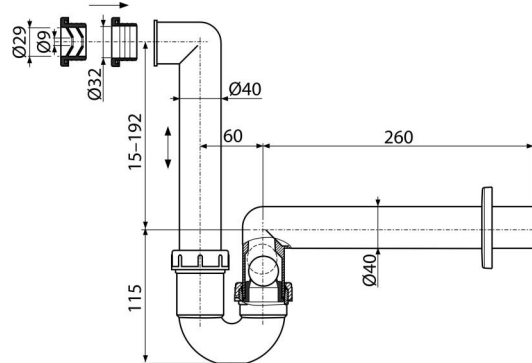

Application

To capture the dripping condensation

Features

- Combined odour trap with a ball
- Material: polypropylene
- Connection to waste pipe Ø40 mm

Scope of supply

- Plastic rosette
- Waste and trap body with a combined odour trap
- Wrapping seal Ø40/10
- Wrapping seal Ø40/32

Order number, Logistic information

Code	EAN	Weight (piece packing palett)	Dimensions (piece packing)	Quantity (packing palett)
AKS2	8595580514808	0,31 4,69 151,3 kg	300×70×190 590×240×390 mm	15 420 pcs

Warranty

2/3 years *

Norms

EN 274

Technical specifications

- Flow with collar S687 38,4 l/min
- Flow with collar S688 3,6 l/min
- Thermal resistance 95 °C
- Odour trap 64 mm