

# A114S/1120

Mounting frame for wall-hung WC and sensor

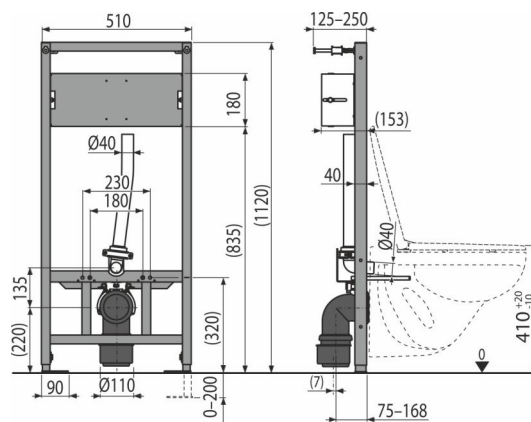

### Application

For automatic flushing systems – sensor  
 For mounting in front of a support wall or in to a plasterboard construction with preparation for mounting the sensor flusher  
 For wall-hung WC with a connecting pitch of 180 mm or 230 mm

### Features

- The frame allows the anchoring to a separate sufficiently strong plasterboard partition, in front of the bearing wall
- Material: powder-coated metal
- Adjustable anchor feet and a spring-lock system, with a range of 0–200 mm
- Prepared for connecting a bracket with a DG 1/2" conversion for bidet seats and sprays
- Universal sensor holder – compatible with other types of sensors

### Scope of supply

- Fixation material for fixing the WC pan: threaded rod M12 – 2 pcs, washers – 4 pcs, cover – 2 pcs, nut – 2 pcs, thread protector – 2 pcs
- Fixation set: screw Ø8x60 – 4 pcs, dowel Ø12 – 4 pcs
- Waste elbow set HT 90/110 polypropylene
- Water supply joint to the WC pan HT 40
- Bracket for mounting the sensor
- Self-supporting frame
- Pipe for water supply to the WC pan from the flusher HT40

### Order number, Logistic information

Code	EAN	Weight (piece   packing   palett)	Dimensions (piece   packing)	Quantity (packing   palett)
A114S/1120	8595580518585	12,93   12,93   214,0 kg	1125x515x75   1125x515x75 mm	1   15 pcs

**Warranty** 2/15 years \*      **Customs code** 73089098

### Technical specifications

- Load test 400 kg