

# AGV2S

Rain drum 300×155/125 mm straight outlet, grey

### Application

For installation outside buildings  
 For draining the rainwater and surface water to sewerage system  
 For connecting gutter downspouts

### Features

- Color: gray
- Limits the transmission of the odours from the sewer
- Eccentric rings for connecting the gutter downspouts 80, 90, 100, 110 and 125 mm
- The material contains UV stabilizers against fading and aging of plastic
- Material: polypropylene enriched with glass fiber – resistant to mechanical, chemical and thermal damage
- Option to buy a stainless steel basket against the invasion of rodents from the waste
- Option to buy a universal insert for round and square gutter downspouts
- Plastic basket can be easily removed and cleaned
- After installation in the interlocking pavement, the visible parts of the rain drum can be swapped for parts in black colour
- Straight outlet – 125 mm
- Steeper gradient of the rain drum body enables a faster and bigger water flow towards the sewer
- Dry odour trap
- The lock prevents unintentional opening of the lid, overflow of water during heavy rains

### Scope of supply

- The flap limiting the transmission of the odours from the sewer
- Basket for catching dirt and leaves
- Set of inlet rings for gutter downspouts diameter 80, 90, 100, 110, 125 mm
- Drain body DN125 mm straight outlet
- Lid with lock

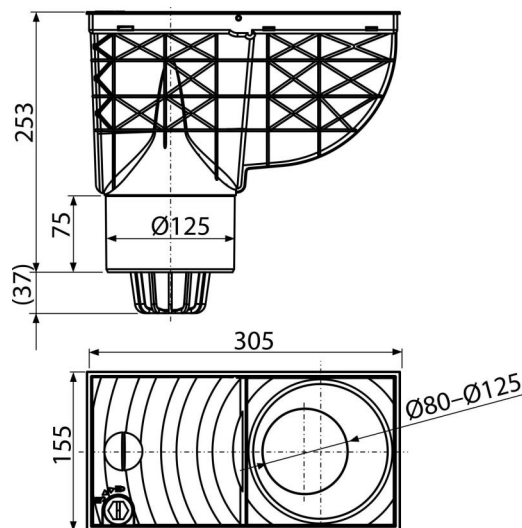

### Order number, Logistic information

Code	EAN	Weight (piece   packing   palett)	Dimensions (piece   packing)	Quantity (packing   palett)
AGV2S	8595580519278	1,14   5,69   111,0 kg	315×265×165   545×335×440 mm	5   80 pcs

Warranty	Customs code	Norms
2/6 years *	39269097	EN 1253, EN 1451

### Technical specifications

- Flow rate 390 l/min