

# APV0006

Stainless steel flange seal

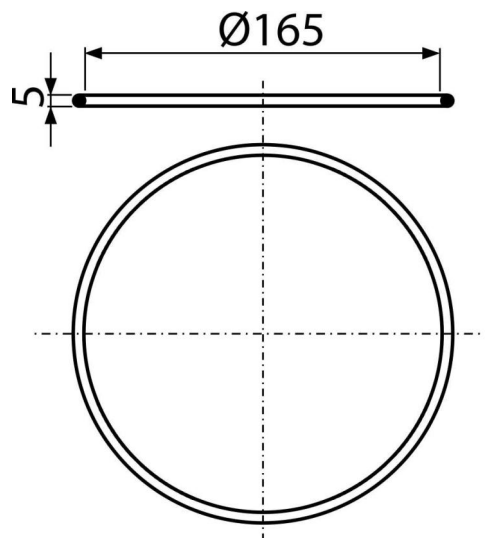

### Application

For floor drains with stainless steel flange

### Features

- Material: rubber (NBR)
- Ensures increased sealing of the stainless steel flanges

### Scope of supply

- Sealing ring

### Order number, Logistic information

Code	EAN	Weight (piece   packing   palett)	Dimensions (piece   packing)	Quantity (packing   palett)
APV0006	8595580522483	0,0054   0,0054   - kg	165×5×165   - mm	1   - pc

### Warranty

2/2 years \*