

APV0800

Drain throat extension neck DN105

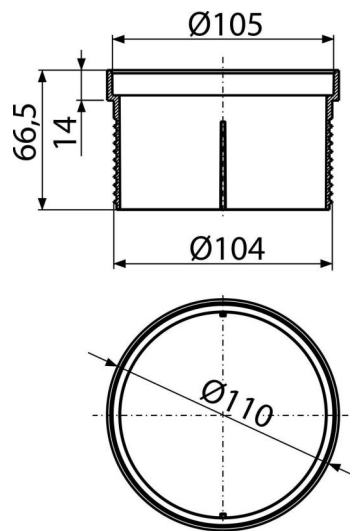

Application

For floor drains
For use indoors and outdoors
To extend the drain throat

Features

- Material: polypropylene resistant to mechanical, chemical and thermal damage
- Possibility to use multiple attachments
- Horizontal folding for easier height adjustment of the throat and fixation in the floor

Scope of supply

- Drain throat extension
- Seal

Order number, Logistic information

Code	EAN	Weight (piece packing palett)	Dimensions (piece packing)	Quantity (packing palett)
APV0800	8595580523084	0,07 0,07 - kg	110x68x110 - mm	1 - pc

Warranty

2/2 years *