

# AGV3S

Rain drum 300x155/110 mm side outlet, grey

## Application

For installation outside buildings  
 For draining the rainwater and surface water to sewerage system  
 For connecting gutter downspouts

## Features

- Locking sleeve for fixation of rain drum in the ground
- Color: gray
- Side connection to waste Ø110 mm
- Limits the transmission of the odours from the sewer
- Eccentric rings for connecting the gutter downspouts 80, 90, 100, 110 and 125 mm
- The material contains UV stabilizers against fading and aging of plastic
- Material: polypropylene enriched with glass fiber – resistant to mechanical, chemical and thermal damage
- Option to buy a stainless steel basket against the invasion of rodents from the waste
- Option to buy a universal insert for round and square gutter downspouts
- Plastic grid to capture dirt
- After installation in the interlocking pavement, the visible parts of the rain drum can be swapped for parts in black colour
- Dry odour trap
- The lock prevents unintentional opening of the lid, overflow of water during heavy rains
- Stopper against shifting the rain drum into the drum throat

## Scope of supply

- The flap limiting the transmission of the odours from the sewer
- Set of inlet rings for gutter downspouts diameter 80, 90, 100, 110, 125 mm
- Grid to capture coarse dirt
- Drain body DN110 mm side outlet
- Lid with lock

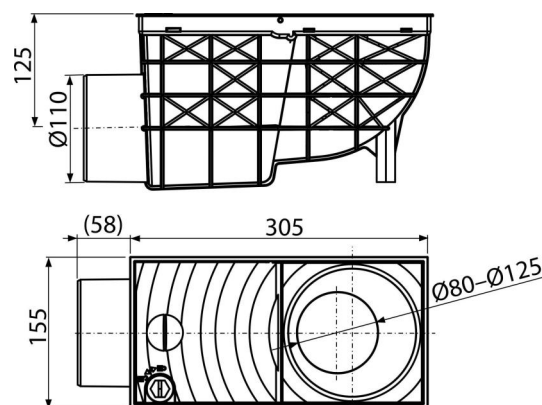

## Order number, Logistic information

Code	EAN	Weight (piece   packing   palett)	Dimensions (piece   packing)	Quantity (packing   palett)
AGV3S	8595580524036	1,05   4,19   145,6 kg	360x160x195   400x345x385 mm	4   120 pcs

Warranty	Customs code	Norms
2/6 years *	39269097	EN 1253, EN 1451

## Technical specifications

- Flow rate 486 l/min