

APV0060

Dry odour trap for APV26, APV26C

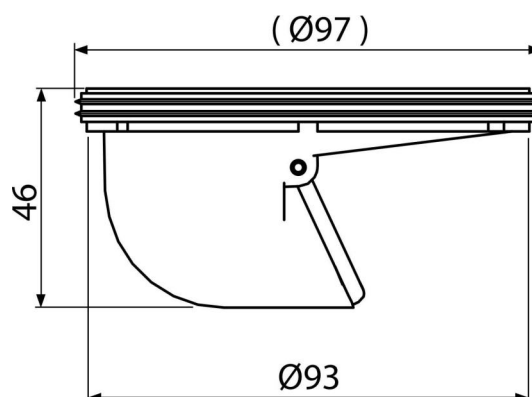

Application

For floor drains APV26, APV26C
For outdoor use

Features

- Material: polypropylene resistant to mechanical, chemical and thermal damage
- Mechanical closure of dry odour trap prevents the penetration of odours from the sewer

Scope of supply

- Odour trap flap
- Odour trap body
- Seal

Order number, Logistic information

Code	EAN	Weight (piece packing palett)	Dimensions (piece packing)	Quantity (packing palett)
APV0060	8595580531508	0,07 3,39 114,9 kg	98×46×98 590×240×390 mm	50 1400 pcs

Warranty

2/2 years *

Norms

EN 1253

Technical specifications

- Pressure resistance 260 Pa
- Flow rate 57-62 l/min