

AKS5

Funnel trap for dripping condensate with tube holder DN32

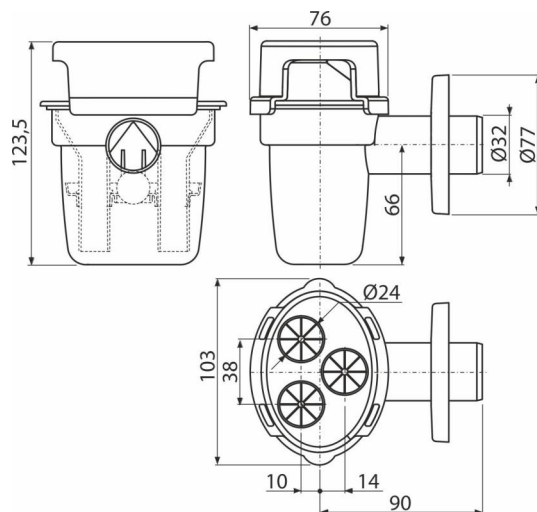

Application

To capture the dripping condensation

Features

- Holder for condensation tubes with no direct connection to the trap – dripping is visible
- Combined odour trap with a ball
- Material: polypropylene
- Possibility to connect up to three sources of condensation
- Connection to waste pipe Ø32 mm

Scope of supply

- Tubing holder
- Plastic rosette
- Waste and trap body with a combined odour trap

Order number, Logistic information

| Code | EAN | Weight (piece packing palett) | Dimensions (piece packing) | Quantity (packing palett) |
|------|---------------|--------------------------------------|---------------------------------|--------------------------------|
| AKS5 | 8595580531683 | 0,16 9,71 175,4 kg | 130×100×125 590×390×430 mm | 60 960 pcs |

Warranty

2/3 years *

Norms

EN 274

Technical specifications

- Flow rate 10,8 l/min
- Odour trap 50 mm