

P095

Set of combined odour traps for stainless steel shower drains ALCA (standard building height)

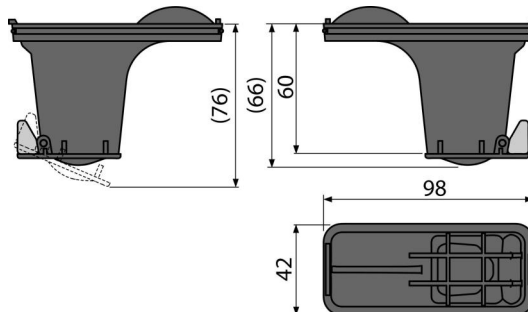

Application

For shower drains: APZ1, APZ4, APZ5, APZ6, APZ11, APZ1001, APZ1004, APZ1006,

ARZ1

For areas that are expected to have low usage of the shower enclosure

Features

- Combined odour trap SMART

Scope of supply

- Combined odour trap
- Grid trap for coarse dirt 2 pcs

Order number, Logistic information

Code	EAN	Weight (piece packing palett)	Dimensions (piece packing)	Quantity (packing palett)
P095	8595580532741	0,11 0,11 - kg	160x60x200 - mm	1 - pc

Warranty
2/2 years *

Norms
EN 1253

Technical specifications

- Flow rate 60-68,8 l/min
- Odour trap 50 mm