

# SA08AK 3/8" CHROM

Fill and flush kit with DUAL control button

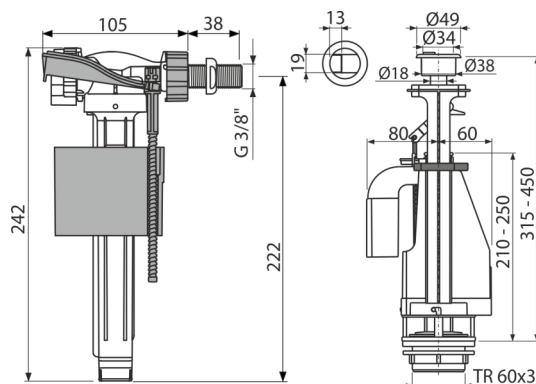

### Application

For ceramic flushing cistern  
For replacement

### Features

- STOP button to adjust the amount of discharged water
- The design allows optimum height adjustment of the valve according to the height of the cistern
- Metal thread length 38 mm
- Low sensitivity to the changing pressure in the water main
- Option of the setting the button off the axis of the valve
- Adjustable water level
- Smooth closing without any shocks
- DUAL button chrome
- DUAL flush mechanism 3/6 l
- Built-in filter to trap dirt

### Scope of supply

- Fixation set: screw M8x65 – 2 pcs
- Inlet fill valve A160-3/8"
- Seal kit
- Flush valve A08A
- Stopper Chrome

### Order number, Logistic information

Code	EAN	Weight (piece   packing   palett)	Dimensions (piece   packing)	Quantity (packing   palett)
SA08AK 3/8" CHROM	8595580532826	0,78   12,54   220,6 kg	400x200x100   590x430x390 mm	16   256 pcs

### Warranty

2/3 years \*

### Norms

EN 14124, EN 14055

### Technical specifications

- Acoustic group II <30 dB
- Recommended operating pressure 0,5-0,8 MPa
- Functional requirements class I
- Flush volume of single flushes is determined by the size and the volume of the tank
- Working range 0,05-0,8 MPa
- Height adjustment range 315-450 mm