

A108F/1100

Mounting frame with cistern for a waste sink with waste connection DN90/110 and faucet

Application

For mounting wall fittings
 For mounting in front of a support wall or in to a plasterboard construction
 For a wall-hung waste sink with a spacing of anchor bolts up to 420 mm and waste connection Ø90/110

Features

- Dual flush independently adjustable with hygienic reserve
- The construction of polystyrene insulation prevents condensation forming on the surface of the tank and dampens the vibrations from the tank into the building structure
- The frame allows the anchoring to a separate sufficiently strong plasterboard partition, in front of the bearing wall
- The service opening cover simplifies assembly and prevents the penetration of moisture and impurities
- Material: powder-coated metal
- Installation depth adjustable from 20–95 mm
- The cistern is made of one piece, thus ensuring 100% impermeability
- The installed module is covered with a plasterboard panel and there is no need for any additional fixing or anchoring elements
- Adjustable telescopic feet, range 0–200 mm
- Swivel rail for attaching wall fittings with a pitch of 65–150 mm
- Water supply from the rear/top
- For leading Wall Fittings
- Angle valve with the ability to connect to the Mepla piping system
- Maintenance work without using any tools
- Mounting depth 125 mm, with waste elbow 160 mm
- Built-in tanks allows for rinsing the waste sink
- Height adjustable partitions

Scope of supply

- Fixation material for fixing the WC pan: threaded rod M12 – 2 pcs, washers – 4 pcs, cover – 2 pcs, nut – 2 pcs, thread protector – 2 pcs
- Fixation set: screw Ø8x60 – 4 pcs, dowel Ø12 – 4 pcs
- Waste elbow HT 90/110 with a seal
- The 2 piece cover of the service opening is simply adjustable
- Cistern with fill and flush valve
- Connection fittings G1/2"–G1/2"
- Self-supporting frame
- Fittings 1/2" water connection with the integrated angle valve Schell 1/2–3/8"
- Drainage seal, PP connector, connector seal
- Inlet seal, PP outlet, wrapping seal

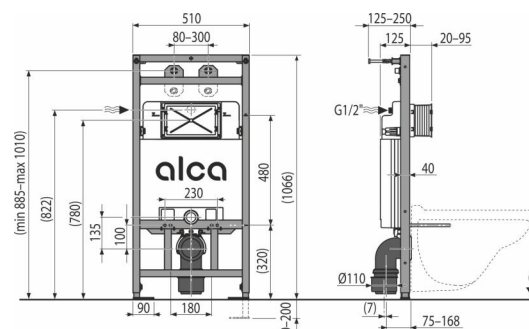

Order number, Logistic information

Code	EAN	Weight (piece packing palett)	Dimensions (piece packing)	Quantity (packing palett)
A108F/1100	8595580542139	15,86 15,86 257,9 kg	1107x515x139 1107x515x139 mm	1 15 pcs

Warranty

2/15 years *

Technical specifications

- Recommended range of water pressure 0,3-0,6 MPa
- Functional range of water pressure 0,05-0,8 MPa
- Hygienic reserve 3 l
- Small flush 2,5-3,5 l
- Water volume in the cistern 9 l
- Water connection from the back or top via mounting holes G1/2 "
- Factory setting of small flush 3 l
- Factory setting of large flush 6 l
- Big flush 6-9 l
- Load test 400 kg