

# P148Z

Double connector G1"/17-23 with valves

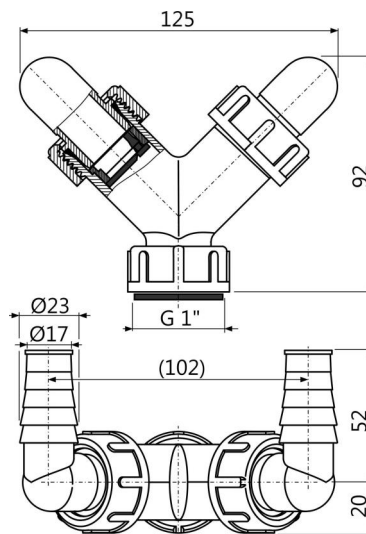

### Application

For the connection of up to two appliances  
 For washing machines and other traps  
 Connects various appliances to the waste pipe

### Features

- Two connectors for various electrical appliances – washing machines, dishwashers, etc.
- Valves with partition serve to direct the flow of water into the waste
- Nut G1" for connecting to trap
- The red plug is used for blinding the connector if it is not used.

### Scope of supply

- Connector 17-23 mm – 2 pcs
- Connector body
- Seal
- Connector seals 2 pcs
- Stoppers 2 pcs
- Return valve 2 pcs

### Order number, Logistic information

Code	EAN	Weight (piece   packing   palett)	Dimensions (piece   packing)	Quantity (packing   palett)
P148Z	8595580544973	0,11   7,40   227,2 kg	125x72x94   590x390x240 mm	70   1960 pcs

Warranty 2/2 years \*      Customs code 39174000

### Technical specifications

- Double hose connection 17-23 mm