

P148

Double connector G1"/17-23

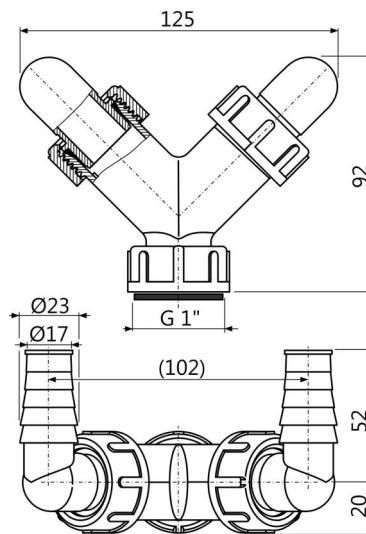

Application

For the connection of up to two appliances
 For washing machines and other traps
 Connects various appliances to the waste pipe

Features

- Two connectors for various electrical appliances – washing machines, dishwashers, etc.
- Nut G1" for connecting to trap
- The red plug is used for blinding the connector if it is not used.

Scope of supply

- Connector 17-23 mm – 2 pcs
- Connector body
- Seal
- Connector seals 2 pcs
- Stoppers 2 pcs

Order number, Logistic information

| Code | EAN | Weight (piece packing palett) | Dimensions (piece packing) | Quantity (packing palett) |
|------|---------------|--------------------------------------|---------------------------------|--------------------------------|
| P148 | 8595580544980 | 0,10 6,98 215,4 kg | 125x72x94 590x390x240 mm | 70 1960 pcs |

Warranty 2/2 years * Customs code 39174000

Technical specifications

- Double hose connection 17-23 mm