

# AVZ102R-R102S

Outdoor drain box for AVZ102 with plastic frame and galvanized "C" profile grid A15

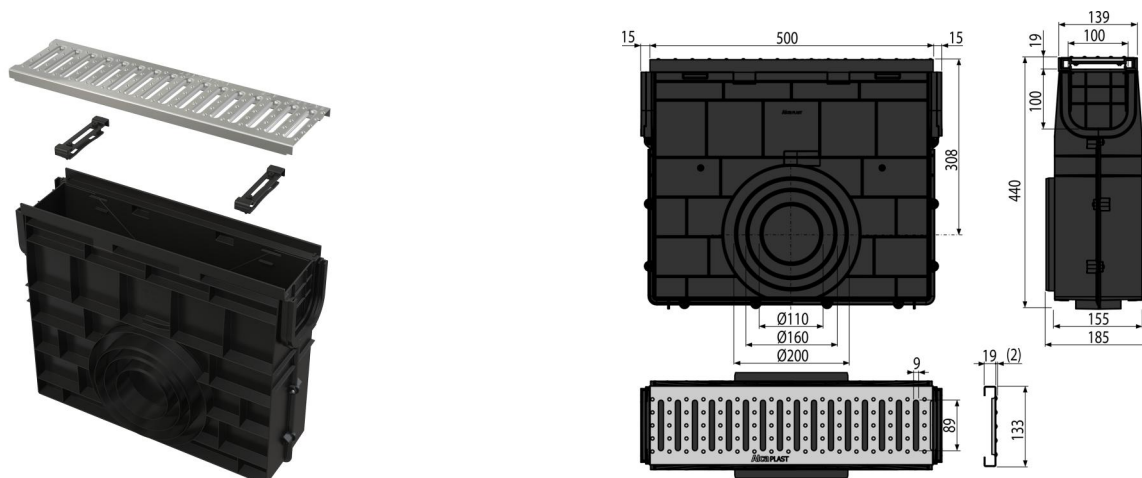

## Application

For cleaning and maintenance of outdoor drain channels  
For outdoor drain channels AVZ102

## Features

- Side connection to waste DN110, 160, 200 mm
- Numerous ribbing for a firm fixation within surrounding material
- Material with UV stabilizer against aging, fading and degradation of plastic
- Material: polypropylene filled with talc resistant to mechanical, chemical and thermal damage
- Galvanized grid with "C" profile – fixed to the drain by two plastic locks, inlet slit width 9 mm
- Sophisticated and solid locking mechanism for simple connection of the individual drains
- Robust construction – self-supporting
- Serves to collect dirt and sand from roads and pavements
- Easy access to the floor drain – simple cleaning
- Lock system allows easy connecting without additional fixing elements

## Scope of supply

- Galvanized grid profile "C" – load class A15
- Drain box body
- Locks for fixing the grid to the drain, 2 pcs

## Order number, Logistic information

Code	EAN	Weight (piece   packing   palett)	Dimensions (piece   packing)	Quantity (packing   palett)
AVZ102R-R102S	8595580547783	3,91   3,91   113,9 kg	532x186x425   532x425x186 mm	1   24 pcs

**Warranty** 2/6 years \*      **Customs code** 39269097

## Technical specifications

- Load class A15 1500 kg