

AVZ101R-R124R

Outdoor slotted drain box with symmetrical access cover 160 mm, galvanized steel

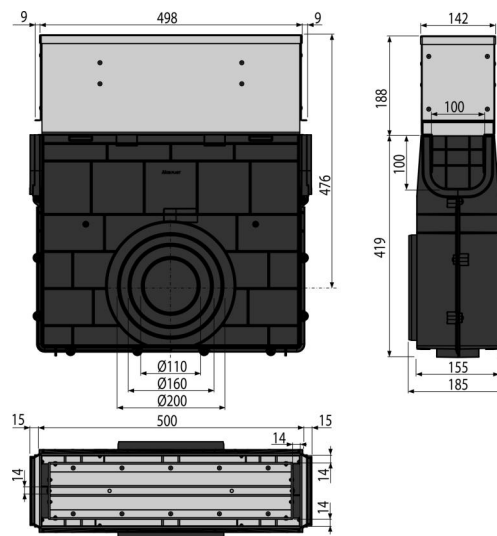

Application

For cleaning and maintenance of outdoor drain channels
For outdoor drain channels AVZ101S-R124R

Features

- Side connection to waste DN110, 160, 200 mm
- Numerous ribbing for a firm fixation within surrounding material
- Material of extention: galvanized steel
- Material with UV stabilizer against aging, fading and degradation of plastic
- Material of drain channel: polypropylene filled with talc resistant to mechanical, chemical and thermal damage
- Sophisticated and solid locking mechanism for simple connection of the individual drains
- Access cover – easy removal for routine maintenance of the drain
- Robust construction – self-supporting
- Serves to collect dirt and sand from roads and pavements
- Easy access to the floor drain – simple cleaning
- Lock system allows easy connecting without additional fixing elements

Scope of supply

- Galvanized access cover
- Drain box body

Order number, Logistic information

Code	EAN	Weight (piece packing palett)	Dimensions (piece packing)	Quantity (packing palett)
AVZ101R-R124R	8595580549886	10,77 10,77 343,0 kg	607x516x185 607x185x516 mm	1 30 pcs

Warranty

2/6 years *

Norms

EN1433

Technical specifications

- Load class C250 25000 kg