

# AVZ101R-R323R

Outdoor slotted drain box with symmetrical access cover 100 mm, stainless steel

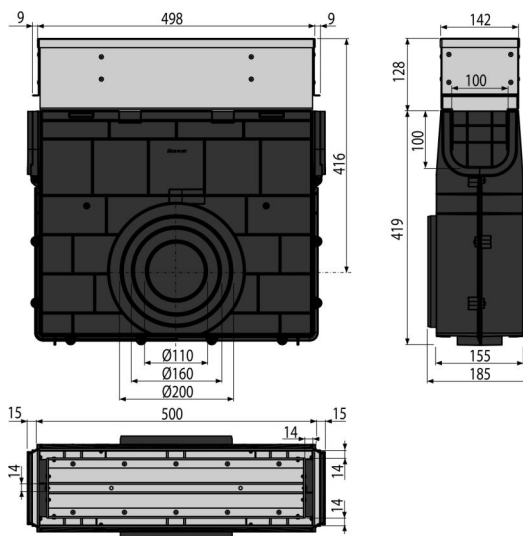
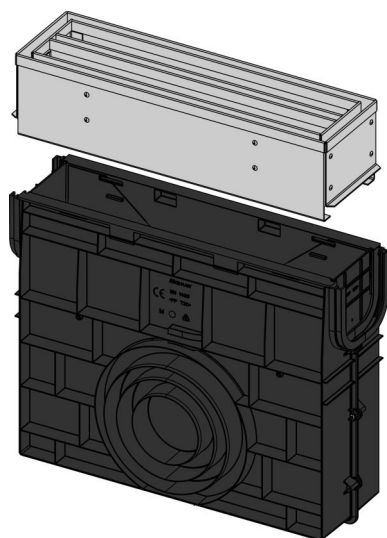

## Application

For cleaning and maintenance of outdoor drain channels  
For outdoor drain channels AVZ101S-R323R

## Features

- Side connection to waste DN110, 160, 200 mm
- Numerous ribbing for a firm fixation within surrounding material
- Material of extension: stainless steel AISI 304, DIN 1.4301
- Material with UV stabilizer against aging, fading and degradation of plastic
- Material of drain channel: polypropylene filled with talc resistant to mechanical, chemical and thermal damage
- Sophisticated and solid locking mechanism for simple connection of the individual drains
- Access cover – easy removal for routine maintenance of the drain
- Robust construction – self-supporting
- Serves to collect dirt and sand from roads and pavements
- Easy access to the floor drain – simple cleaning
- Lock system allows easy connecting without additional fixing elements

## Scope of supply

- Stainless steel access cover
- Drain box body

## Order number, Logistic information

Code	EAN	Weight (piece   packing   palett)	Dimensions (piece   packing)	Quantity (packing   palett)
AVZ101R-R323R	8595580549916	9,00   9,00   290,0 kg	547x516x185   547x185x516 mm	1   30 pcs

## Warranty

2/6 years \*

## Norms

EN1433

## Technical specifications

- Load class C250 25000 kg