

A104/1120

Mounting frame for wash-basin

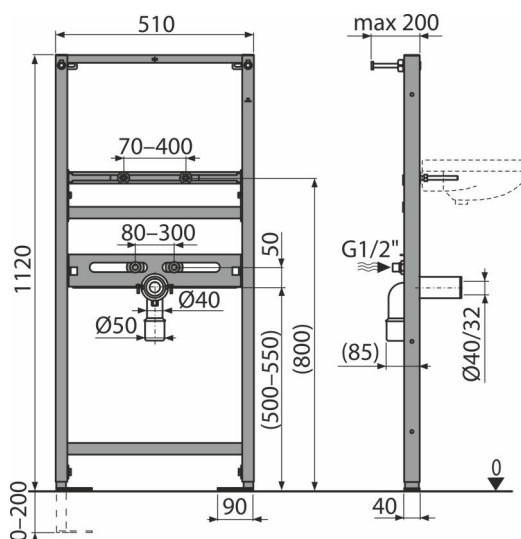

Application

For mounting in front of a support wall or in to a plasterboard construction
 For installation deck mounted faucet
 For wall-hung sinks

Features

- The frame allows the anchoring to a separate sufficiently strong plasterboard partition, in front of the bearing wall
- Material: powder-coated metal
- Adjustable anchor feet and a spring-lock system, with a range of 0–200 mm
- Water supply pitch 80–300 mm
- Self-supporting frame
- Height adjustable partitions

Scope of supply

- Fixation material for washbasins: bolt M10×100 – 2 pcs
- Fixation set: screw Ø8×60 – 4 pcs, dowel Ø12 – 4 pcs
- Covers for the fixing material
- Connection fittings G1/2"–G1/2"
- Mounting frame

Order number, Logistic information

Code	EAN	Weight (piece packing palett)	Dimensions (piece packing)	Quantity (packing palett)
A104/1120	8595580551544	8,26 8,26 267,9 kg	1125×515×75 1125×515×75 mm	1 30 pcs

Warranty

2/15 years*

Norms

EN 14688

Technical specifications

- Load test 150 kg