

# APZ-S9

Low trap DN50 and set of adjustable legs

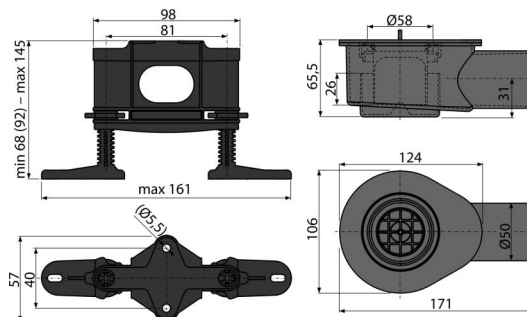

## Application

For drainage of floor-level showers  
For shower drains APZ13, APZ23

## Features

- Material: polypropylene, thermally and chemically resistant, longitudinally welded
- Mechanically cleanable trap up to the waste pipe
- Rotatable trap
- Installation height from 81 mm

## Scope of supply

- Nut M6 2 pc
- Adjustable feet 4 pcs
- Trap safety lock 2 pcs
- Waste and trap body
- Odour trap

## Order number, Logistic information

Code	EAN	Weight (piece   packing   palett)	Dimensions (piece   packing)	Quantity (packing   palett)
APZ-S9	8595580551605	9 mm 0,48   13,55   - kg	253x118x100   mm	28   - pc

**Warranty** 2/2 years \*      **Customs code** 39229000

## Technical specifications

- Resistance of odour trap against the pressure 380 Pa
- Flow rate 50 l/min
- Odour trap 30 mm