

APZ-S12

Trap DN50 and set of adjustable legs

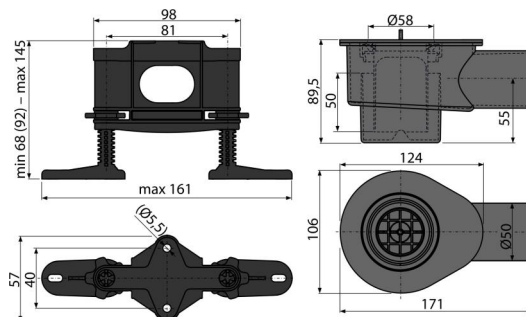

Application

For drainage of floor-level showers
For shower drains APZ13, APZ23

Features

- Material: polypropylene, thermally and chemically resistant, longitudinally welded
- Mechanically cleanable trap up to the waste pipe
- Rotatable trap
- Installation height from 105 mm

Scope of supply

- Nut M6 2 pc
- Adjustable feet 4 pcs
- Trap safety lock 2 pcs
- Waste and trap body
- Odour trap

Order number, Logistic information

Code	EAN	Weight (piece packing palett)	Dimensions (piece packing)	Quantity (packing palett)
APZ-S12	8595580551612	12 mm 0,50 14,00 - kg	253x118x100 mm	28 - pc

Warranty 2/2 years * **Customs code** 39229000

Technical specifications

- Resistance of odour trap against the pressure 540 Pa
- Flow rate 58 l/min
- Odour trap 50 mm