

# APV110

Floor drain stainless steel extra-low 130×130 mm side outlet, without grid, combined odour trap SMART

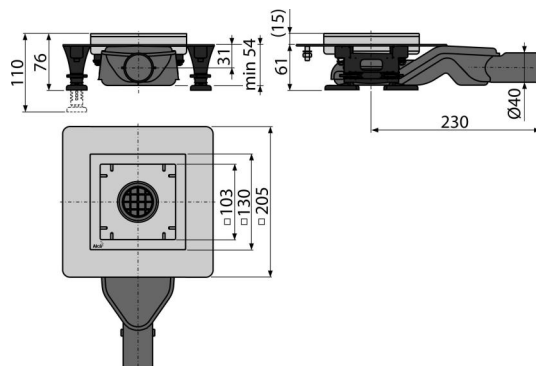

## Application

For wheelchair access  
 For drainage of floor level showers  
 For the interior, where will be frequent use associated with the regular water runoff into the floor drain (bathrooms) – combined odour trap SMART

## Features

- Side connection to waste Ø40 mm
- Material of trap: polypropylene resistant to mechanical, chemical and thermal damage
- Material of floor drain: stainless steel AISI 304, DIN 1.4301, DIN 17240
- Mechanically cleanable trap up to the waste pipe
- Wide insulation collar for connection to waterproofing construction
- Installation height from 54 mm

## Scope of supply

- Dismantling hook
- Installation drain cover
- Combined odour trap
- Plastic foot APZ13 UNI 4 pcs
- Self-adhesive waterproofing tape
- Trap for shower drain APZ13-S6
- Odour trap tray

## Order number, Logistic information

Code	EAN	Weight (piece   packing   palett)	Dimensions (piece   packing)	Quantity (packing   palett)
APV110	8595580555160	1,92   11,53   250,5 kg	335×207×73   mm	6   120 pcs

Warranty  
 2/25 years \*

Norms  
 EN 1253

## Technical specifications

- Total installation height 76-110 mm
- Resistance of odour trap against the pressure 270 Pa
- Waste pipe diameter 40 mm
- Flow rate 40 l/min
- Load class K3 300 kg
- Odour trap 31 mm