

P128

Extraction fan for pre-wall installation systems with ventilation

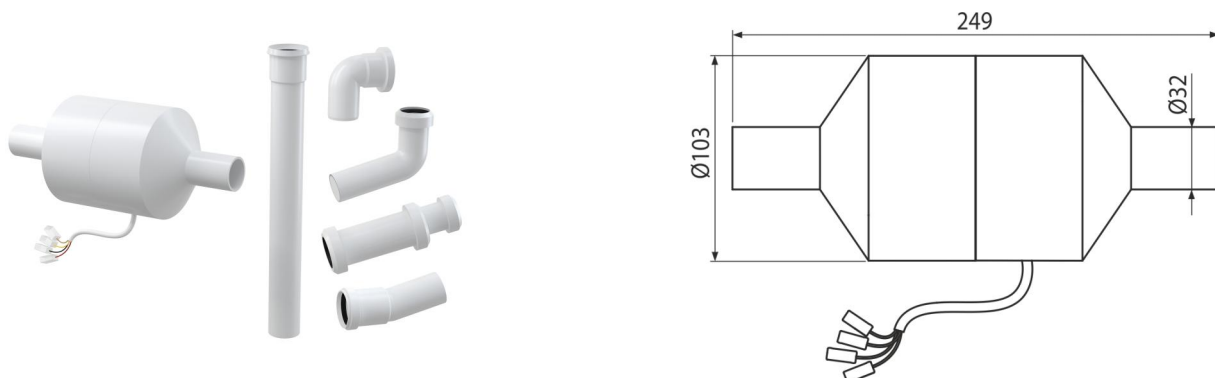

Application

For extraction of odours from the toilet bowl
For pre-wall installation systems AM115/1000V, AM101/1120V, AM102/1120V

Features

- Color: white
- Material: plastic
- Odour removal directly from the WC bowl

Scope of supply

- Extraction fan + set of connectors, as shown above

Order number, Logistic information

Code	EAN	Weight (piece packing palett)	Dimensions (piece packing)	Quantity (packing palett)
P128	8595580558215	1,01 7,04 132,6 kg	350x225x125 mm	7 112 pcs

Warranty

2/2 years *

Technical specifications

- Wiring: 230 V 50 Hz 15 W
- Degree of protection: IP X4
- Air extraction power: 52 m³/h