

C148Z

Double connector G1"/17-23 with return valves

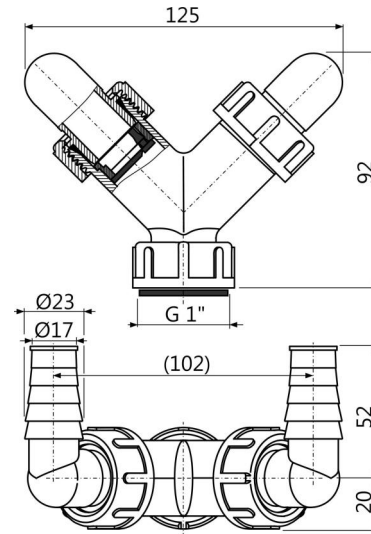

Application

For the connection of up to two appliances
 For washing machines and other traps
 Connects various appliances to the waste pipe

Features

- Two connectors for various electrical appliances – washing machines, dishwashers, etc.
- Nut G1" for connecting to trap
- The barrier directs the flow of water, reducing the risk of back flow into the second connector
- The red plug is used for blinding the connector if it is not used.
- Return valve prevents the backflow of water, this solution is suitable for systems that lack their own return valves

Scope of supply

- Connector 17-23 mm – 2 pcs
- Connector body
- Seal
- Connector seals 2 pcs
- Stoppers 2 pcs
- Return valve 2 pcs

Order number, Logistic information

Code	EAN	Weight (piece packing palett)	Dimensions (piece packing)	Quantity (packing palett)
C148Z	8595580564582	0,11 5,56 155,5 kg	125x72x94 590x390x240 mm	70 1960 pcs

Warranty

2/2 years

Technical specifications

- Double hose connection 17-23 mm