

A150-3/8"

Side inlet fill valve for ceramic WC cisterns

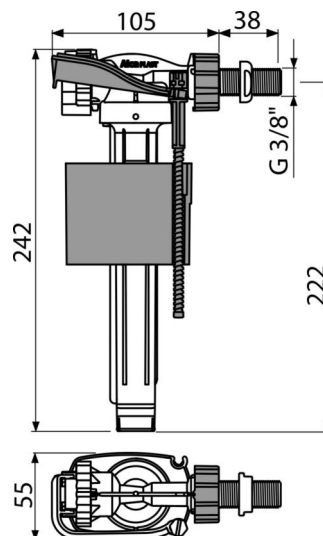

Application

For installation on the side of the cistern
For replacement
Universal valve for ceramic WC cisterns

Features

- Low sensitivity to the changing pressure in the water main
- Material: POM
- Adjustable water level
- Plastic thread length 38 mm
- Smooth closing without any shocks
- Built-in filter to trap dirt

Scope of supply

- Nut 3/8" – white
- Strainer for dirt
- Valve

Order number, Logistic information

Code	EAN	Weight (piece packing palett)	Dimensions (piece packing)	Quantity (packing palett)
A150-3/8"	8595580566685	0,17 12,16 214,5 kg	235x145x60 590x430x390 mm	70 1120 pcs

Warranty
2/6 years *

Norms
EN 14124

Technical specifications

- Acoustic group I <20 dB
- Recommended operating pressure 0,5-0,8 MPa
- Working range 0,05-1,6 MPa
- Thread diameter 3/8 "