

APR3-1120

Industrial point drain 150×150, stainless steel AISI 316L

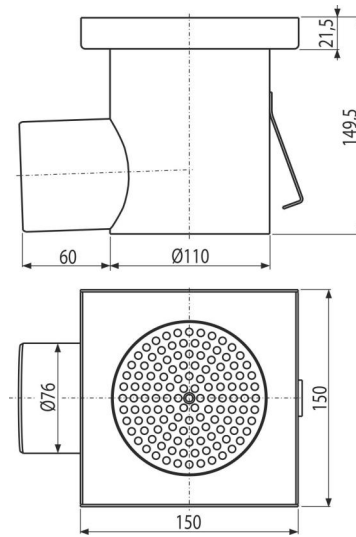

Application

To drain large amount of water, suitable also for long distances
For drainage of large industrial facilities, and other commercial facilities inside buildings, eg. in the chemical and food industries

Features

- Floor drain material: stainless steel 1.5 mm, DIN 1.4404
- Strong anchoring in concrete with simply adjustable legs and side anchors
- Adjustable feet
- Industrial drain made of stainless steel (heat treated by pickling and passivation), this process guarantees that the stainless steel even after several years keeps its properties and reliable operation
- High flow rate

Scope of supply

- Strainer to capture the dirt
- Adjustable feet 4 pcs
- Sealings 1 pc
- Floor drain
- Odour trap

Order number, Logistic information

Code	EAN	Weight (piece packing palett)	Dimensions (piece packing)	Quantity (packing palett)
APR3-1120	8595580573546	2,16 2,16 - kg	150×150×170 150×150×170 mm	1 - pc

Warranty

2/5 years *

Norms

EN 1253-1

Technical specifications

- Wet odour trap 50 mm