

APR7-1211-20

Industrial point drain with slot inlets 250×250, stainless steel AISI 304

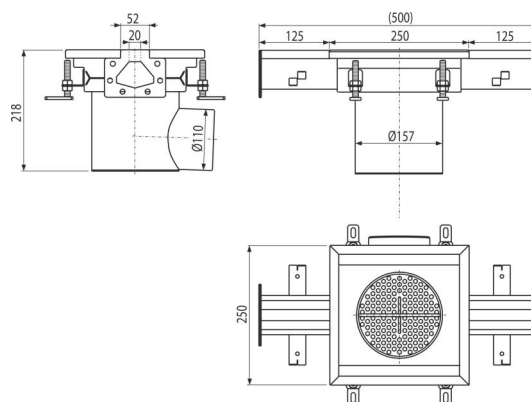
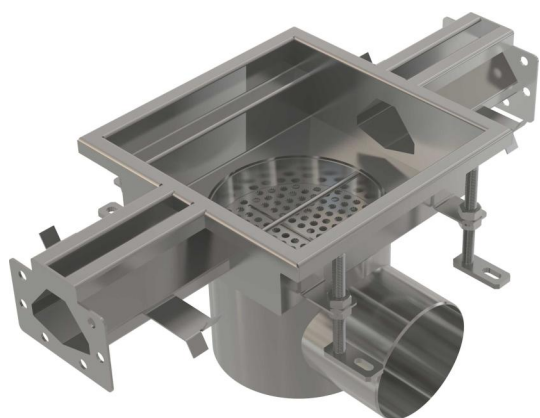

Application

For drainage with low water flow
For drainage of large industrial facilities, and other commercial facilities inside buildings, eg. in the chemical and food industries

Features

- Floor drain material: stainless steel 1.5 mm, DIN 1.4301
- Strong anchoring in concrete with simply adjustable legs and side anchors
- Used sealing ensures a completely watertight joint
- Easy cleaning and maintenance
- Adjustable height in the range of 85–125 mm
- Industrial drain made of stainless steel (heat treated by pickling and passivation), this process guarantees that the stainless steel even after several years keeps its properties and reliable operation

Scope of supply

- Fixation set
- Strainer to capture the dirt
- Adjustable feet 4 pcs
- Seal 2 pcs
- Floor drain
- Odour trap

Order number, Logistic information

Code	EAN	Weight (piece packing palett)	Dimensions (piece packing)	Quantity (packing palett)
APR7-1211-20	8595580573744	5,12 5,12 - kg	500×250×218 mm	1 - pc

Warranty

2/5 years *

Norms

EN 1253-1

Technical specifications

- Wet odour trap 50 mm