

APS6

Concealed washing machine trap for connecting two appliances, stainless steel DN40 and DN50

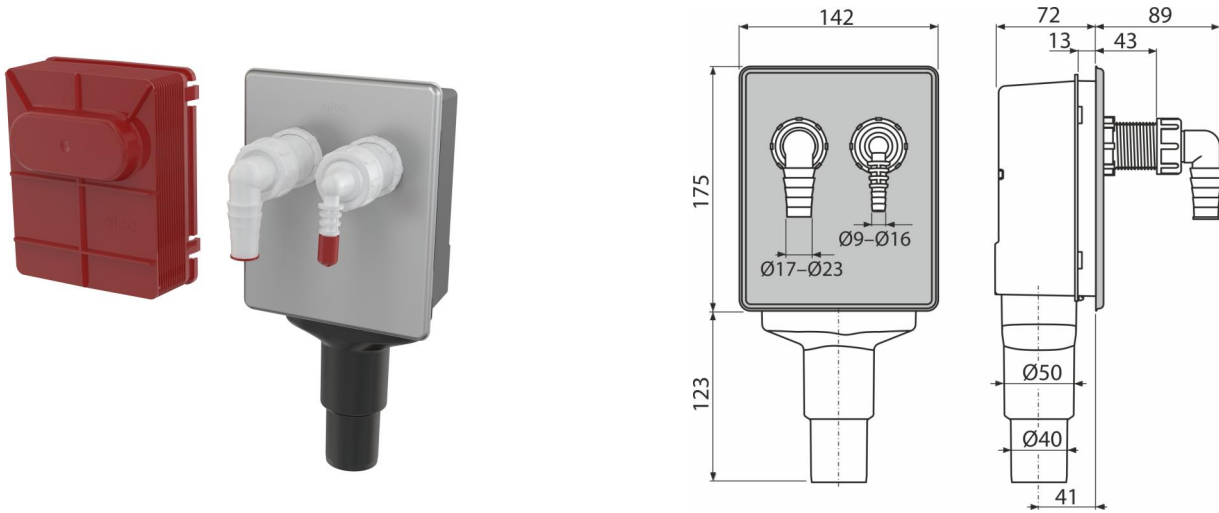

Application

For installation under plaster
For connecting two appliances

Features

- Material: polypropylene
- Connection to HT 40/50
- Service access for easy cleaning

Scope of supply

- Elbow 17–23 mm - 1 pc, Elbow 8–16 mm 1 pc
- Stainless steel cover
- Construction cap
- Waste and trap body

Order number, Logistic information

Code	EAN	Weight (piece packing palett)	Dimensions (piece packing)	Quantity (packing palett)
APS6	8595580578473	0,78 14,11 245,7 kg	300×165×150 580×380×420 mm	18 288 pcs

Warranty	Customs code	Norms
2/3 years *	39229000	EN 274

Technical specifications

- Flow rate 16,8 l/min
- Thermal resistance 95 °C
- Odour trap 50 mm