

AS-P124

Installation frame for concealed washing machine trap for connection of two appliances

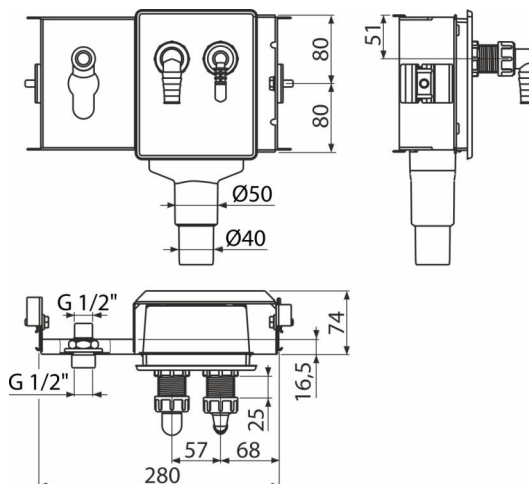

Order number, Logistic information

Code	EAN	Weight (piece packing palett)	Dimensions (piece packing)	Quantity (packing palett)
AS-P124	8595580578541	2,10 2,10 - kg	mm	1 - pc