

A107S/1120

Mounting frame for urinal and sensor

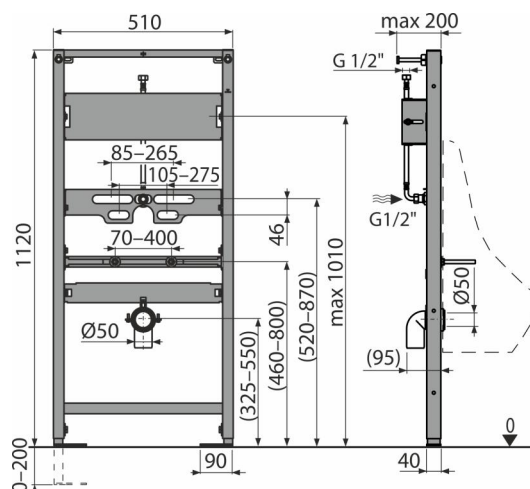

Application

For automatic flushing system (sensor) before the bearing wall or into a

plasterboard structure

For mounting in front of a support wall or in to a plasterboard construction

For wall-hung urinals

Features

- The frame allows the anchoring to a separate sufficiently strong plasterboard partition, in front of the bearing wall
- Material: powder-coated metal
- Adjustable anchor feet and a spring-lock system, with a range of 0–200 mm
- Waste pipe adjustable 0–110 mm from center
- Water connection adjustable 0–125 mm from center
- Universal sensor holder – compatible with other types of sensors
- Height adjustable partitions

Scope of supply

- Fixing hardware for mounting the urinal: M10 screw – 2 pcs
- Fixation set: screw Ø8×60 – 4 pcs, dowel Ø12 – 4 pcs
- Bracket for mounting the sensor
- Covers for the fixing material
- Self-supporting frame

Order number, Logistic information

Code	EAN	Weight (piece packing palett)	Dimensions (piece packing)	Quantity (packing palett)
A107S/1120	8595580578985	9,98 9,98 319,3 kg	1125×515×75 1125×515×75 mm	1 30 pcs

Warranty 2/15 years* **Customs code** 73089098

Technical specifications

- Load test 150 kg