

AS101-SET02-PR

Prefabricated system wall

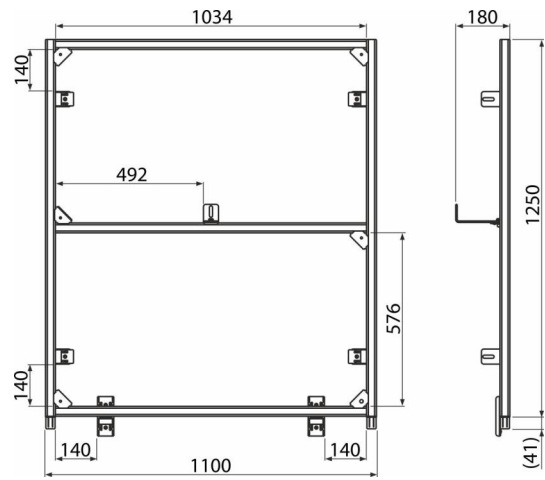

Order number, Logistic information

Code	EAN	Weight (piece packing palett)	Dimensions (piece packing)	Quantity (packing palett)
AS101-SET02-PR	8595580581411	10,08 - - kg	mm	1 pc