

# P156Z-ECO-1900

Double connector DN40/32 / 8-23 with valves

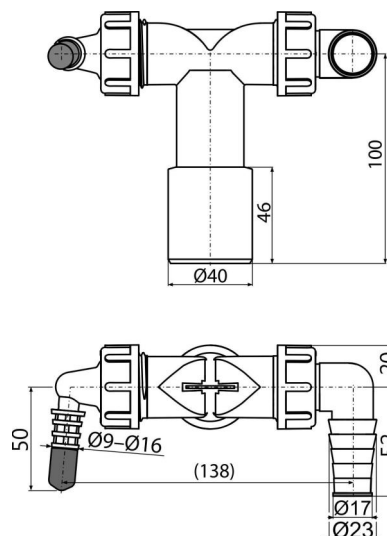
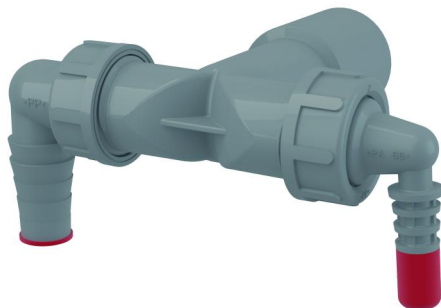

### Application

For the connection of up to two appliances  
For washing machines and other traps  
Connects various appliances to the waste pipe

### Features

- Two connectors for various electrical appliances – washing machines, dishwashers, dryers, boilers, air conditioning, heat recovery, etc.
- Valves with partition serve to direct the flow of water into the waste
- Material: recycled polypropylene
- Low carbon footprint
- Direct connection to HT DN40/DN32 – no need of another trap when installing additional household appliance
- Made in Czech Republic
- Zero waste production process
- The red plug is used for blinding the connector if it is not used.

### Scope of supply

- Elbow 17-23 mm - 1 pc, Elbow 8-16 mm 1 pc
- Connector body
- Seal
- Connector seals 2 pcs
- Plug 1 pc
- Return valve 2 pcs

### Order number, Logistic information

Code	EAN	Weight (piece   packing   palett)	Dimensions (piece   packing)	Quantity (packing   palett)
P156Z-ECO-1900	8595580582593	0,11   5,53   108,4 kg	125x72x94   590x390x240 mm	50   800 pcs

### Warranty

2/2 years

### Technical specifications

- Hose connector 8-16 mm
- Hose connector 17-23 mm
- Thread for connection to the trap 1 "