

A90-90P50A

WC connector – Elbow 90° with connecting pitches DN50

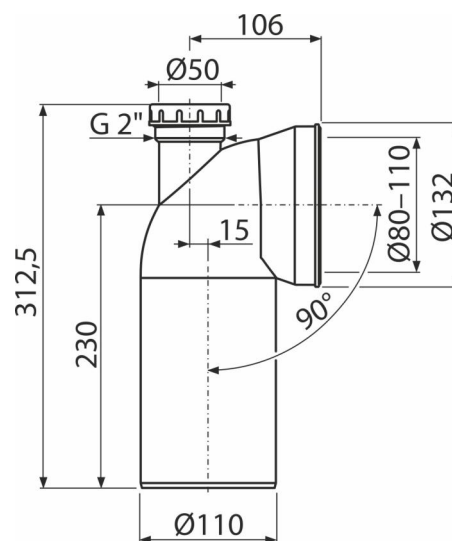

Application

To connect the WC bowl to the drain pipe

Features

- Material: polypropylene
- Possibility of connecting washbasin waste outlet Ø50 mm or an air admittance valve.
- Waste outlet connection 110 mm
- Inclination angle 90°

Scope of supply

- Elbow
- Seal

Order number, Logistic information

Code	EAN	Weight (piece packing palett)	Dimensions (piece packing)	Quantity (packing palett)
A90-90P50A	8595580585808	0,46 5,52 108,4 kg	313x146x135 590x430x390 mm	12 192 pcs

Warranty

2/2 years *