

A80-DN50/40

Pipe trap with coupling nut 6/4" and flexi pipe

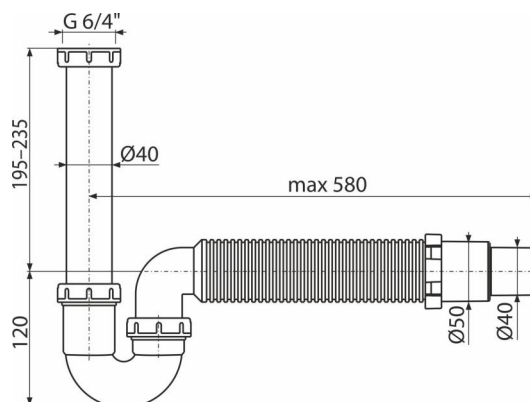

Application

For sink

Features

- Material: polypropylene
- Connection to waste pipe Ø50 mm

Scope of supply

- Flexi pipe
- Nut to connect sink waste 6/4"
- Waste and trap body

Order number, Logistic information

Code	EAN	Weight (piece packing palett)	Dimensions (piece packing)	Quantity (packing palett)
A80-DN50/40	8595580586089	0,39 5,84 - kg	310x80x200 590x240x390??? mm	15 240.....??? pcs

Warranty

2/3 years *

Norms

EN 274

Technical specifications

- Flow rate 60 l/min
- Thermal resistance 95 °C
- Odour trap 64 mm